

TS-ARMATUR

HEATING, HOT WATER

REFRIGERATION & PLUMBING

SOLUTIONS

TS ARMATUR

E-Mail: Sales_support@ts-armatur.se

Ron.Zhan@ts-armatur.se

Website: www.tsarmatur.se

Factory address:

No.67 Jinhai Avenue, CN317608, Yuhuan, Zhejiang Province, China

E-Mail: info@ts-valve.com(factory)

Tel: +86-576-87446227(factory)

CATALOGUE 2023

TS



**HEATING, HOT WATER
Refrigeration &
Plumbing Solutions**



Fittings for Heat pumps

TS ARMATUR >>

- a subsidiary to TS Valve, the leading manufacturer of valves and fittings for heating and cooling applications

Founded in 2023, TS ARMATUR relies on more than two decades of experience in specialized components, particularly for heat pumps. We offer products with high quality and reliability at an affordable cost and can provide customized products at short notice.

Since the beginning of the millennium TS Valve has, in close cooperation with some of Europe's leading heat pump manufacturers, become the top provider of valves and fittings for sustainable heating and cooling applications. The company offers a wide range of specialized components for HVAC applications in general, and heat pumps in particular.

Our large variety of products include,

- > safety valves
- > air vents
- > pressure reducing valves,
- > ball filters
- > thermostatic mixing valves and
- > electric shifting/mixing valves



TS Valve has a very well-equipped tool shop, which enables us to produce customized products at short notice and at an affordable cost. Customized parts can include several functions in one and help save both material and costs. This makes us a system provider with fast assembly click connections, safety&mixing valve groups, special R290 safety assemblies and much more.

The close cooperation with leading European manufacturers has gained TS Valve a hard-earned reputation for high quality and reliability, which today is our most valued asset. We have strict control over our manufacturing process and product quality. Our core products have all passed CE, WRAS, RoHs, ACS and other internationally renowned certifications. The production is certified according to both ISO9001 and ISO14001. Innovation is the driving force for development. We work continuously on improving and adding new technology to our products. Today TS Valve holds over 60 national patents and more have been filed for.

TS Valve is trusted by customers all over the world, but our main market is Europe. Today we export our products to, amongst others, Sweden, Norway, Denmark, Finland, Germany, France, Italy and the United Kingdom.

The company acronym TS stands for "Together. Success". The idea of win-win solutions is a core value in our company culture. We strongly believe that with our products we add to the value of our customers products, which contribute to a more sustainable development of our society, a healthier world for us humans. The success of our customers makes us successful.

In 2023 TS Valve founded TS Armatur and therewith opened a base for the company in Europe. TS Armatur brings our products and services closer to our key customers and market. We warmly welcome existing- and new customers in Europe to cooperate with us at TS Armatur and become successful. Together.



CONTENTS

P.01-03

**Safety
valves**



P.08-14

**Zone
Valves**



P.18-19

**Air&Dirt
Separators**



P.04-07

**Combination
Valves and
Safety Groups**



P.15-17

**Temperature
Control Valve
Groups**



P.20-26

**Ball Valves
and Ball Check
Valves**



P.27-29

**Filter
Valves**



P.34-36

**Heating
System Accessories**



P.39-40

Air Vents



P.30-33

Fittings

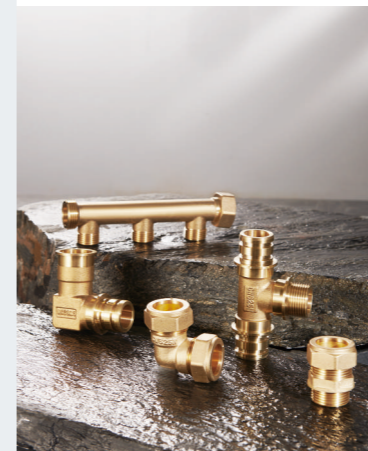

P.37-38

Check Valves



P.41-42

**Assembled
Wall Mounting
Manifolds**



P.43-44

Actuators



P.45-46
**Pressure gauge &
Temperature gauge**

Safety valves

Safety valves are typically used for pressure control on heat generators in heating systems, on hot water storage units in hydraulic and domestic water systems, and in hydraulic systems. On reaching the setting pressure, the valve opens and, by discharging into the atmosphere, prevents the pressure in the system from reaching dangerous levels.

Technical features

setting pressure	1.5-2-2.5-3-6-7-8-9-10bar
max opening pressure	Pset+15%Pset
min closing pressure difference	Pset-15%Pset
thread standard	ISO 228/1
gauge connection	ISO 7/1

construction

body	CW617N/CW625N
diaphragm	EPDM
spring socket	PA66+GF30
spring	Carbon steel 82B
control knob	ABS



TS 211T

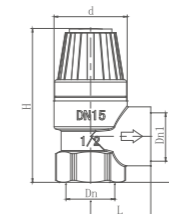

Code	Dn	Dn1	L	h	H	d
211T	1/2"	1/2"	25.5	19.5	65.5	Ø31
211T	3/4"	3/4"	27.5	24	75.5	Ø31
211T	3/4"	1"	36.8	34	88.5	Ø31

Code	Dn	Dn1	Dn2	h1	h2	L1	L2	H	d
213T	1/2"	1/2"	1/4"	21.5	14	24	25.5	71	Ø31
213T	3/4"	3/4"	1/4"	24.5	16.5	24	27.5	74.5	Ø31

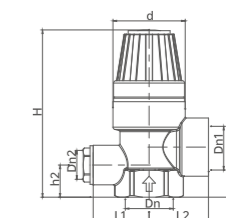

TS 213T

TS 212T

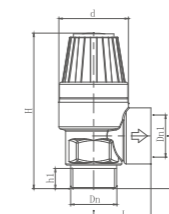

Code	Dn	Dn1	L	h	h1	H	d
212T	1/2"	1/2"	25.5	23.5	9	69.5	Ø31
212T	1/2"	3/4"	33	28	9	75	Ø31
212T	3/4"	3/4"	33	34	10	75	Ø31

Code	Dn	Dn1	L	h	H	d
211-M	3/4"	3/4"	33.5	30	92	Ø37

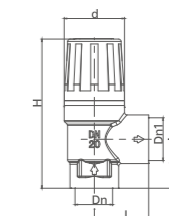

TS 211-M

TS 211433T

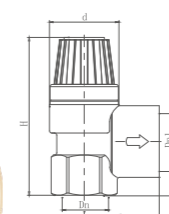

Code	Dn	Dn1	L	h	H	d
211433T	1/2"	3/4"	33.5	24	71	Ø31

Safety Valves

TS 168500

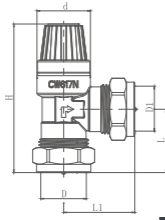

Code	Dn	Dn1	L	h	H	d
168500	Ø22	Ø22	37	41.5	86	Ø31

Code	Dn	Dn1	L	h	H	d
168000	1/2"	Ø15	23	39	71	Ø31

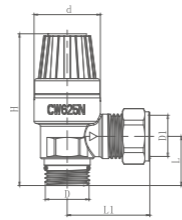

TS 168000

TS 168501

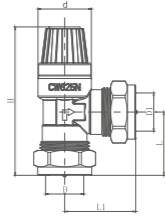

Code	Dn	Dn1	L	h	H	d
168501	Ø22	Ø22	37	41.5	86	Ø31

Code	Dn	Dn1	L	L1	H	d
168503	Ø22	3/4"	41.3	26.5	76	Ø31

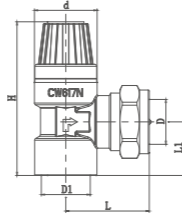

TS 168503

TS 168800

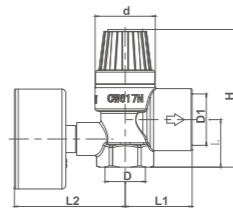

Code	D	D1	L	L1	L2	H	d
168800	1/2"	3/4"	24.5	34.5	57	71	Ø31

Safety Groups

The safety groups are designed to perform the following functions: prevent the water pressure in the tanks from reaching dangerous levels, avoid hot water returning to the cold water circuit and contamination of the water in the storage tank with discharged water, isolate the domestic cold water network and to allow maintenance and control of the tank and the installation.

Technical features

setting pressure	1.5-2-2.5-3-6-7-8-9-10bar
max opening pressure	Pset+15%Pset
min closing pressure difference	Pset-15%Pset
thread standard	ISO 228/1
gauge connection	ISO 228/1

construction

body	CW617N/CW625N
diaphragm	EPDM
spring socket	PA66+GF30
spring	Carbon steel 82B
control knob	ABS/ PA66+GF30



Combination Valves and Safety Groups

TS 7601

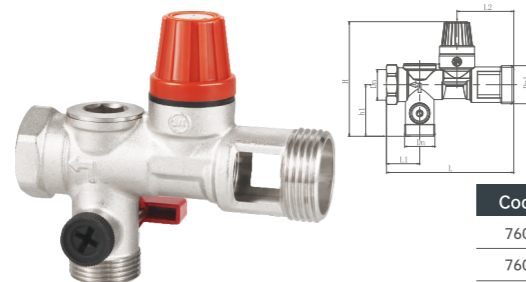

Code	Dn	Dn1	L1	L2	L	h1	H
7601	1/2"	1"	29	49.5	110	45	100
7601	3/4"	1"	29	49.5	110	45	100

TS 166004

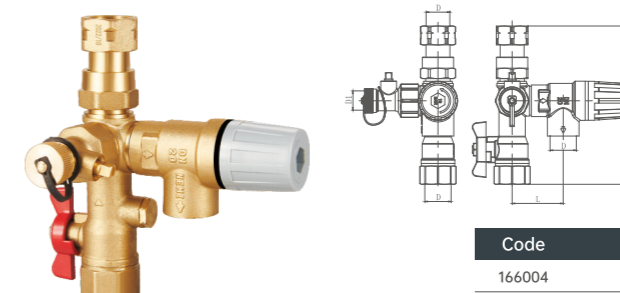

Code	D	D1	L	H
166004	3/4"	1/2"	48.5	150

Combination valves

It is a valve and pipe connection assembly, because of the connection form and Angle of the different, convenient installation and maintenance of the system.

Technical features

max working pressure 10bar
 thread standard ISO 228/1
 gauge connection ISO 228/1

construction

body CW617N/CW625N
 seal EPDM
 drain valve body PA6

TS 166000

Code	D	D1	D2	H1	H
166000	Ø15	Ø22	Ø26	60	131

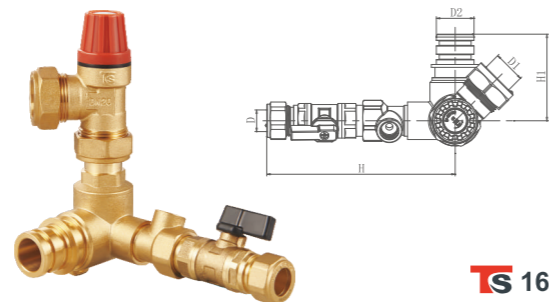

TS 166000

TS 166001

Code	D	D1	H1	L	H
166001	Ø26.1	Ø22	60	72	81

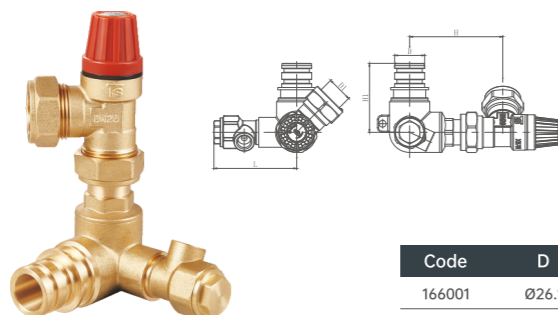

TS 167000

Code	D	H1	H	L
167000	Ø26.1	72	60	65

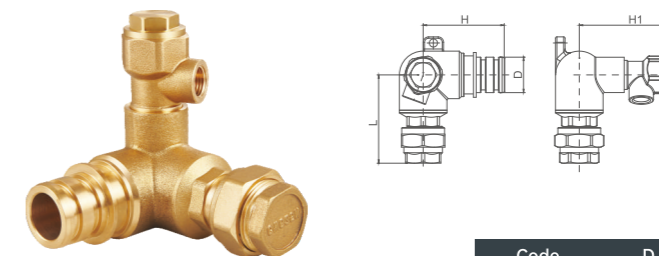

TS 166002

Code	D	D1	D2	L1	L2	H1	H2
166002	Ø22	Ø15	1/2"	67	86.5	51.5	34.5

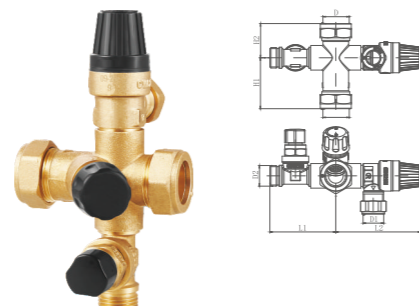

TS 166002

Code	D	L1	L2	L3	L
167001	Ø26.1	48.5	97	76.5	135

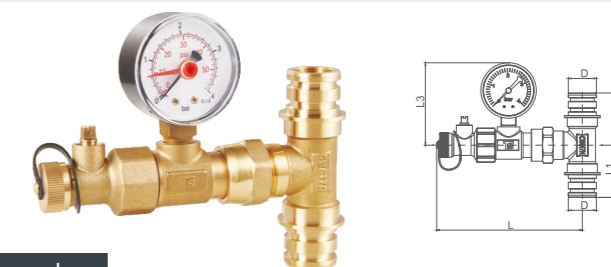

TS 167001

TS 166003

Code	D	D1	D2	H1	H2	L
166003	Ø22	Ø15	1/2"	85	88	106.5

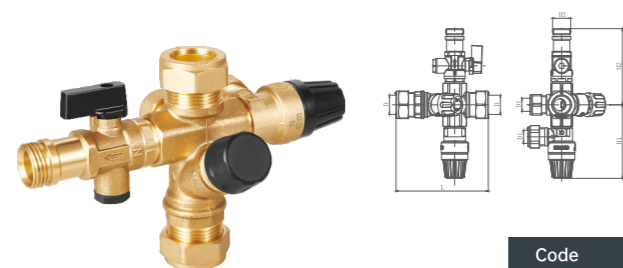

TS 167002

Code	D	H1	H	L
167002	3/4"	Ø26.4	76	110

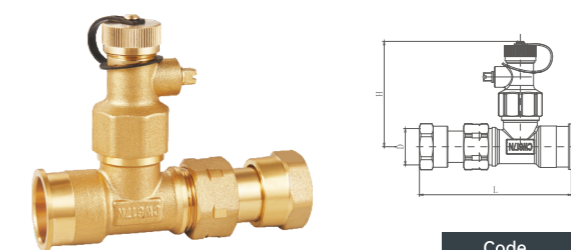

Combination Valves and Safety Groups

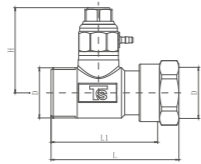

TS 167003

Code	D	H	L1	L
167003	3/4"	44	55	66

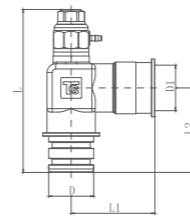

TS 167004

Code	D	D1	L1	L2	L
167004	Ø26.1	Ø26.4	48.5	49	94.5

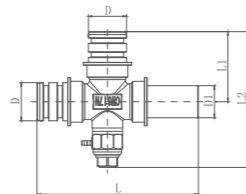

TS 167005

Code	D	D1	L1	L2	L
167005	Ø26.1	Ø22	48	93	110.5

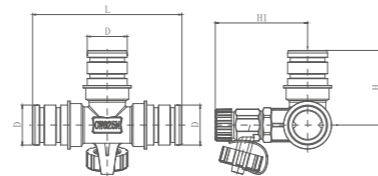

TS 167006

Code	D	H1	H	L
167006	Ø26.1	56	48	96.6
167006	Ø30.8	73	57.5	115

Zone Valves

Zone valves allow automatic shutdown of air conditioning or hydraulic and domestic water medium systems. This specific series of high hydraulic performance horizontal valves, combined with size reduction and field utility, make them particularly suitable for zone heating systems.

Technical features

max working pressure	10 bar
working temperature range	5°C-80°C
media	water, water/glycol
water/glycol	70%/30%
control mode	60°/360°
max working torque	1N*M

construction

body	CW617N
valve plug	PPS
seal	Silicone rubber



Zone Valves

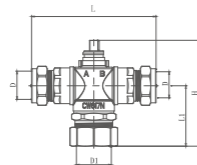

Code	D	D1	L1	L	H
160000	Ø22	Ø28	56	115	98

TS 160000

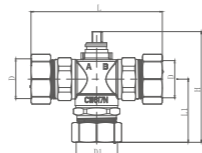

Code	D	D1	L1	L	H
160001	Ø22	Ø22	53.5	115	95.5
160001	Ø28	Ø28	56	116	98

TS 160001

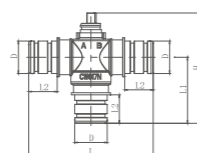

Code	D	L1	L2	L	H
160003	Ø26.1	56.5	21	106	98.5
160003	Ø30.8	62.5	27	118	105

TS 160003

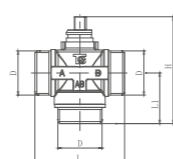

Code	D	L1	L	H
160006	1"	38	62	80
160006	1½"	41	70	83

TS 160006

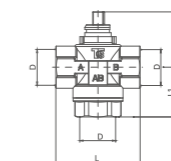
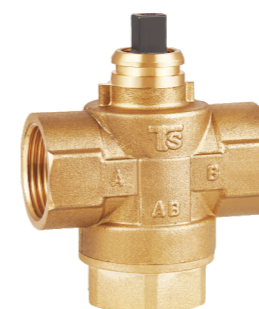

Code	D	L1	L	H
160007	¾"	38	64	80
160007	1"	40	68	82

TS 160007

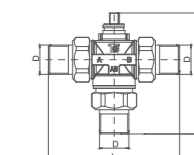
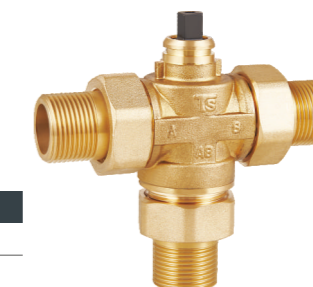

Code	D	L1	L	H
160008	¾"	67	120	109
160008	1"	74	132	116

TS 160008

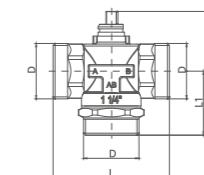

Code	Dn	L1	L	H
160010	1½"	48.5	88	94

TS 160010

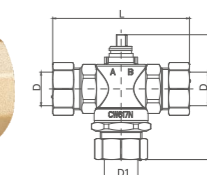

Code	D	D1	L1	L	H
160011	Ø28	Ø28	59	114	98

TS 160011

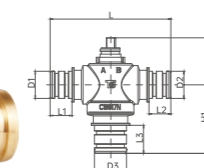

Code	D1	D2	D3	L1	L2	L3	L	H1	H
160013	Ø26.1	Ø26.1	Ø30.8	21	21	27	116	66	111
160013	Ø30.8	Ø26.1	Ø30.8	27	21	27	122	66	111
160013	Ø30.8	Ø30.8	Ø30.8	27	27	27	128	66	111

TS 160013

Zone Valves

Technical features

max working pressure 10 bar
 max working temperature 110°C
 media water, water/glycol
 water/glycol 70%/30%
 control mode 90°/360°
 max working torque 1N*M

construction

body CW617N/CW625N
 valve plug CW617N/CW625N
 ball CW614N/CW617N(Chrome plated)
 valve seat PTFE
 seal EPDM

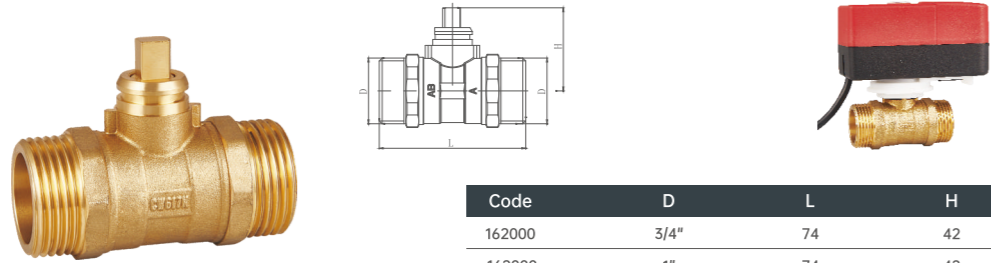

Code	D	L	H
162000	3/4"	74	42
162000	1"	74	42

TS 162000

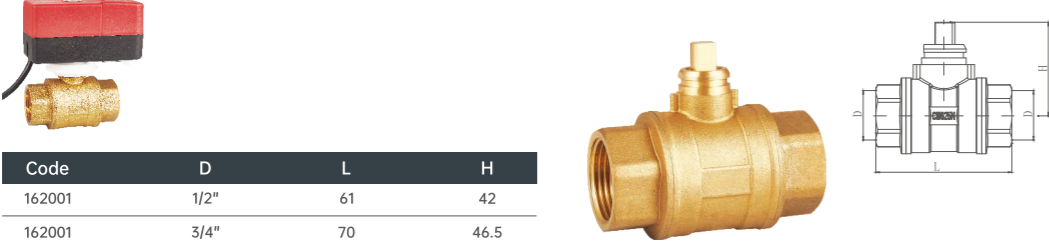

Code	D	L	H
162001	1/2"	61	42
162001	3/4"	70	46.5
162001	1"	85	50

TS 162001

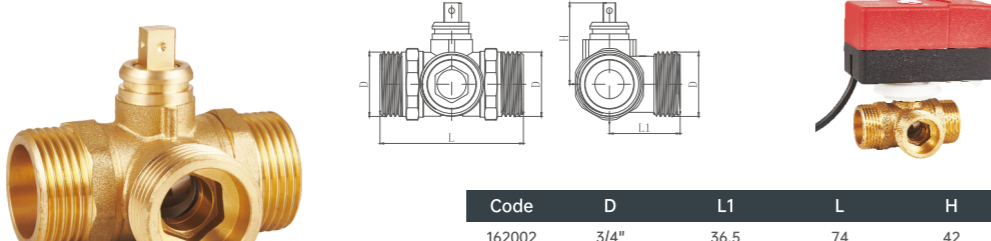

Code	D	L1	L	H
162002	3/4"	36.5	74	42
162002	1"	36.5	74	42

TS 162002

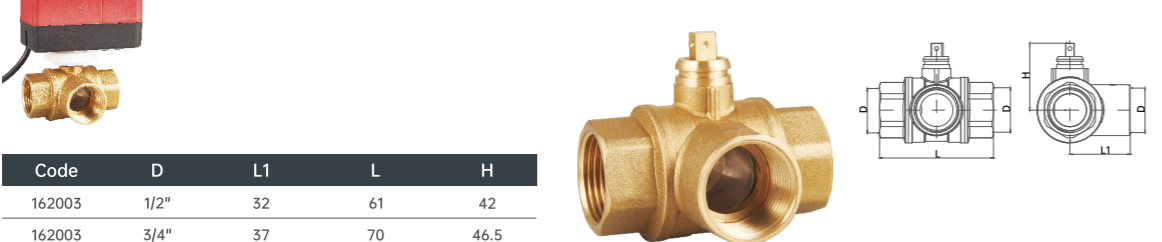

Code	D	L1	L	H
162003	1/2"	32	61	42
162003	3/4"	37	70	46.5
162003	1"	45	85	50

TS 162003



Code	D	L	H
162005	Ø26.1	98	42

TS 162005



Code	D	L1	L	H
162006	Ø26.1	55	98	41

TS 162006

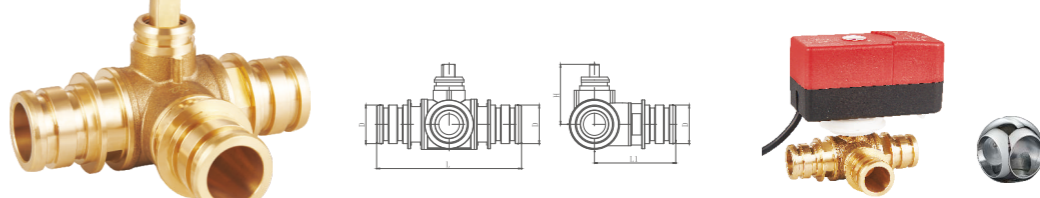

Code	D	L1	L	H
162007	Ø26.1	55	98	41

TS 162007



Code	D	H1	H	L
162008	Ø30.8	67.5	46.5	115

TS 162008

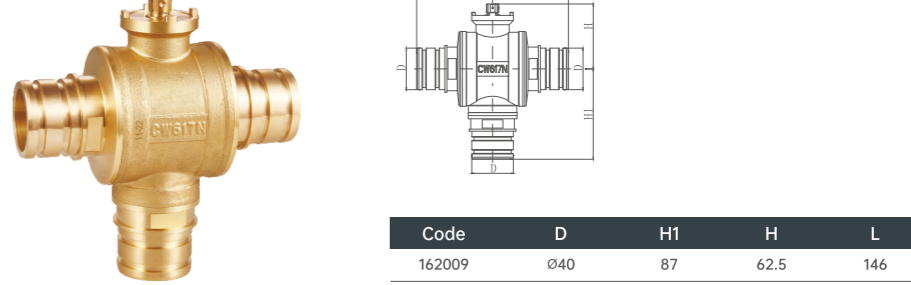

Code	D	H1	H	L
162009	Ø40	87	62.5	146

TS 162009

Zone Valves

Zone valves allow automatic or manual shutdown of air conditioning or hydraulic and domestic water medium systems. This specific series of high hydraulic performance horizontal valves, combined with size reduction and field utility, make them particularly suitable for zone heating systems.

Technical features

max working pressure	10 bar
max working temperature	110°C
media	water, water/glycol
water/glycol	70%/30%
control mode	90°/360°
max working torque	1N*M (electronic control)

construction

body	CW617N/CW625N
valve plug	CW617N/CW625N
valve seat	PTFE
seal	EPDM

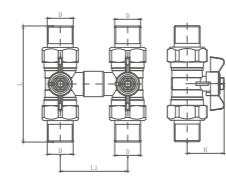

TS 164000

Code	D	L1	L	H
164000	3/4"	69	118	37.5

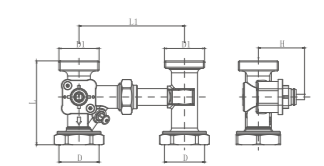

Code	D	D1	L1	L	H
164001	1 1/2"	1 1/2"	90-125	100	55

TS 164001

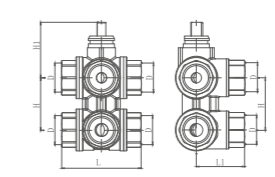

TS 164002

Code	D	L1	L	H1	H
164002	1/2"	37.5	61	42.5	40

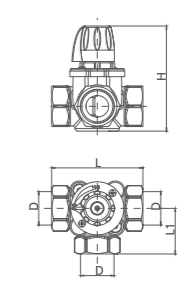

Code	D	L1	L	H
164003	3/4"	36	72	83
164003	1"	36.5	73	83

TS 164003

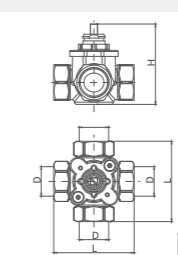

TS 164004

Code	D	L	H
164004	3/4"	72	72
164004	1"	73	72



Temperature Control Valve Groups

Temperature Control Valve Groups are used in systems that produce domestic hot water. It is designed to maintain the preset temperature of the mixed water delivered to the user outlet, when there are variations in the temperature and pressure of the hot and cold water at the inlet, or in the drawn-off flow rate. These devices are also available with fittings complete with strainers and check valves on the hot and cold water inlets.

Technical features

inlet temperature range	min5°C/max90°C
water mixing temperature range	min40°C/max65°C
static working pressure	3 bar
max working pressure	10 bar

construction

body	CW625N
spring	SUS304
seal	EPDM

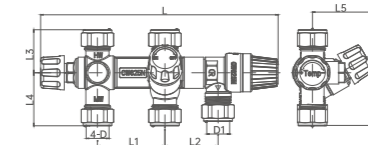

TS 165000

Code	D	D1	L1	L2	L3	L4	L5	L6	L
165000	Ø15	Ø15	54	42.5	34	42	49	43.5	188

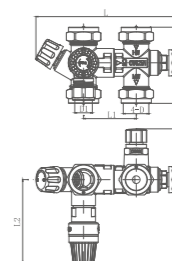

Code	D	D1	L1	L2	L3	L4	L5	L
165001	Ø22	Ø15	55	87	37	42	53	164

TS 165001

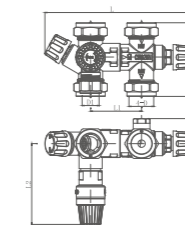

TS 165002

Code	D	D1	L1	L2	L3	L4	L5	L
165002	Ø22	Ø15	55	87	37	42	27	164

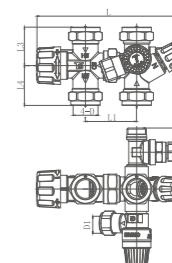

Code	D	D1	L1	L2	L3	L4	L5	L
165003	Ø22	Ø15	55	84.5	41	42.5	65.5	158

TS 165003

Temperature Control Valve Groups

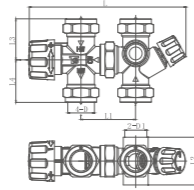

Code	D	D1	L1	L2	L3	L4	L
165004	Ø22	1/2"	55	48	41	42.5	158

TS 165004

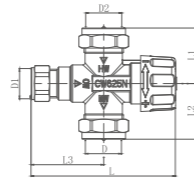

Code	D	D1	D2	L1	L2	L3	L
165005	Ø22	Ø15	22	40.5	40.5	52.5	104.5

TS 165005

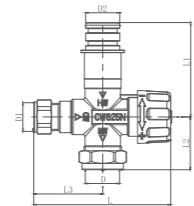

Code	D	D1	D2	L1	L2	L3	L
165006	Ø22	Ø15	26.1	72	40.5	52.5	104.5

TS 165006

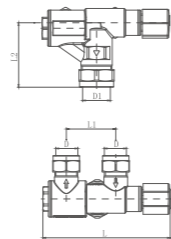
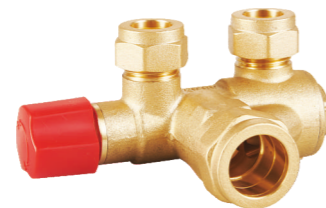

Code	D	D1	L1	L2	L
165007	Ø15	Ø22	45	58.5	116

TS 165007

Air&Dirt Separators

Air & Dirt separators are used to continuously remove the air contained in the hydraulic circuits of heating and cooling systems, down to micro-bubble level. The circulation of fully deaerated water enables the systems to operate under optimal conditions, free from any noise, corrosion, localised overheating or mechanical damage. It is developed especially for R290 Air-Water Heat Pumps in close cooperation with leading Heat Pump manufacturers.

Technical features

max working pressure	10 bar
max water temperature	115°C
thread standard	ISO 228/1

construction

body	CW617N
vent	CW617N
seal	EPDM
floaters	PP



Air&Dirt Separators

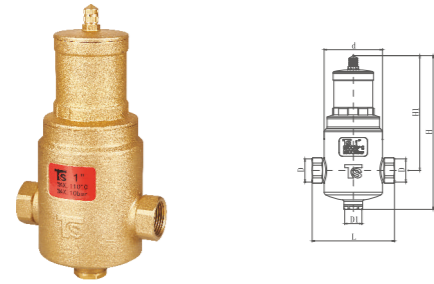

TS 170000

Code	D	D1	d	L	H1	H
170000	1"	1/2"	Ø78	110	154	206
170000	1 1/2"	1/2"	Ø93	128	169	226

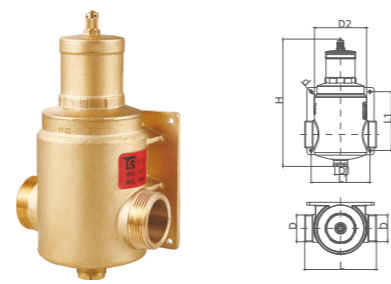

TS 170001

Code	D	D1	D2	d	L1	L	H
170001	1 1/2"	1/2"	Ø93	Ø5.5	105	128	227.5

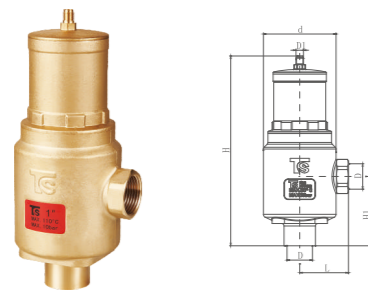

TS 170002

Code	D	D1	d	L	H1	H
170002	1"	M9x1	Ø88	59	84	230

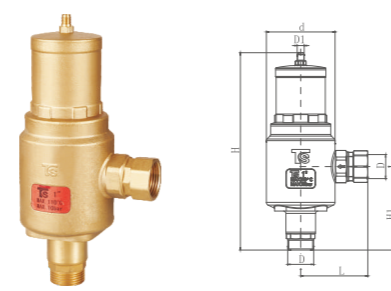

TS 170003

Code	D	D1	d	L	H1	H
170003	1"	M9x1	Ø88	86	107	253

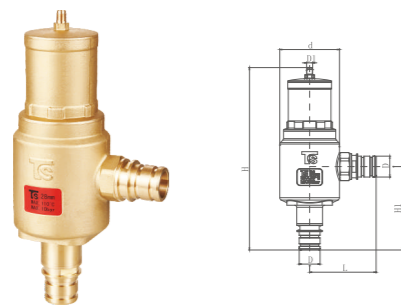

TS 170004

Code	D	D1	d	L	H1	H
170004	Ø30.8	M9x1	Ø88	98	123	269

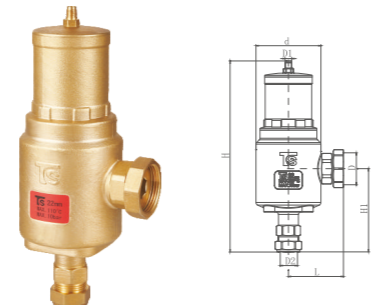

TS 170005

Code	D	D1	D2	d	L	H1	H
170005	1 1/2"	M9x1	Ø22	Ø88	74.5	112.5	258.5

Ball Valves and Ball Check Valves

Ball valves that can be opened and closed quickly in the pipeline system, can realize one-way flow function after integrated check valve in the open state.

Technical features

max working pressure	16 bar(with check valve 10bar)
max working temperature	120°C(with check valve 90°C)
thread standard	ISO 228/1

construction

body	CW617N/CW625N
ball	CW614N/CW617N(Chrome plated)
seal	EPDM
check valve	POM

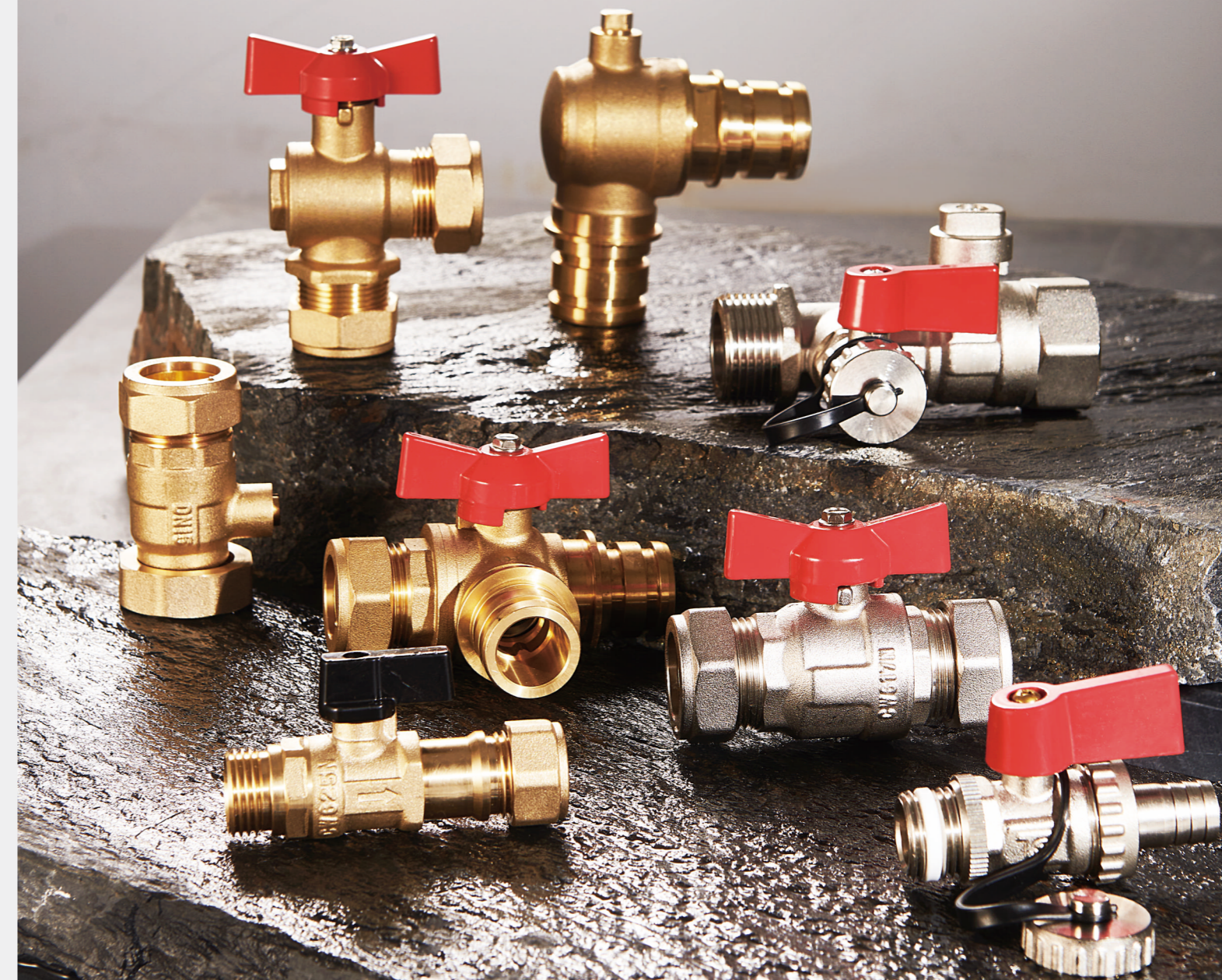

Ball Check Valves

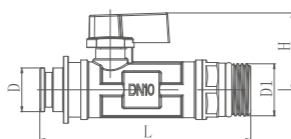

TS 171000

Code	D	D1	L	H
171000	Ø17.6	1/2"	85	31

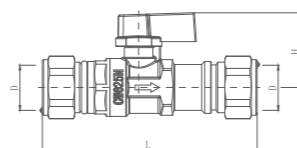

Code	D	L	H
171001	Ø15	88.5	31

TS 171001

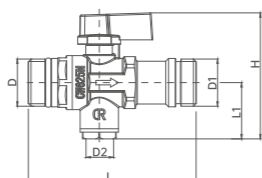

TS 171002

Code	D	D1	D2	L1	L	H
171002	1/2"	1/2"	1/4"	25	74.5	57

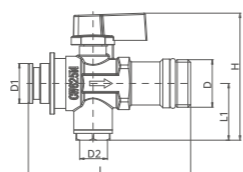

Code	D	D1	D2	L1	L	H
171003	1/2"	Ø17.6	1/4"	25	71.5	57

TS 171003

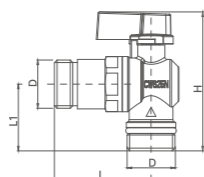

TS 171004

Code	D	L1	L	H
171004	1/2"	29	42	60.5

Ball Valves

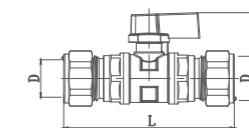

TS 171300

Code	D	L	H
171300	Ø15	80.5	31

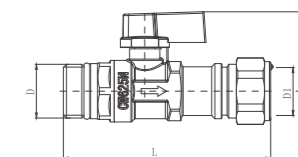

Code	D	D1	L	H
171301	1/2"	Ø15	81	31

TS 171301

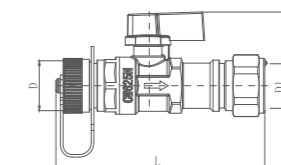

TS 171302

Code	D	D1	L	H
171302	1/2"	Ø15	88	31

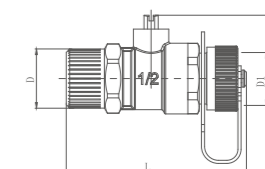

Code	D	D1	L	H
171303	1/2"	1/2"	64	22.5

TS 171303

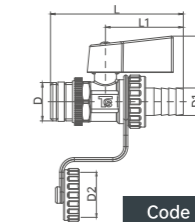
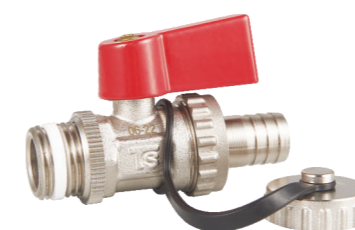

TS 171304

Code	D	D1	D2	L1	L	H
171304	3/8"	Ø15	3/4"	40	67	27.5
171304	1/2"	Ø15	3/4"	42.5	72.5	36

Ball Valves

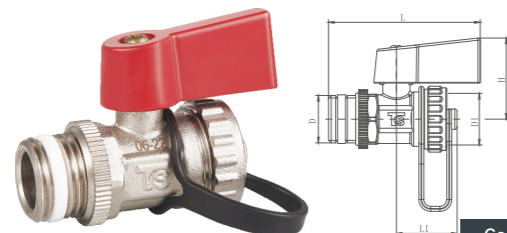

TS 171306

Code	D	D1	L1	L	H
171306	1/2"	3/4"	27	67	36



TS 171312

Code	D	D1	L	H
171312	Ø26.1	3/4"	89	45.5

Code	D	L1	L	H
171308	3/8"	10	40	28
171308	1/2"	12	45	31

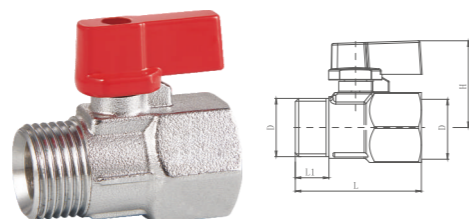

TS 171308

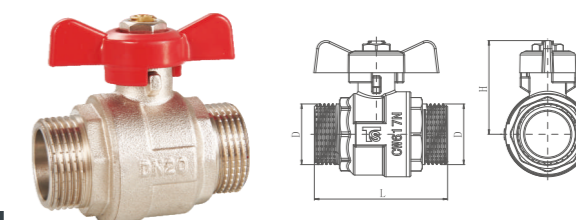

Code	D	L	H
171313	3/4"	58	41

TS 171313

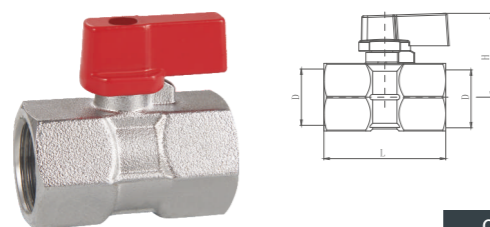

TS 171309

Code	D	L	H
171309	1/2"	45	31

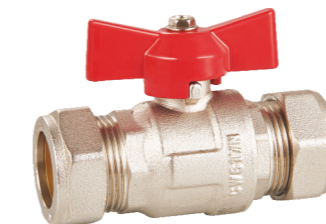

TS 171314

Code	D	L	H
171314	Ø22	84	43

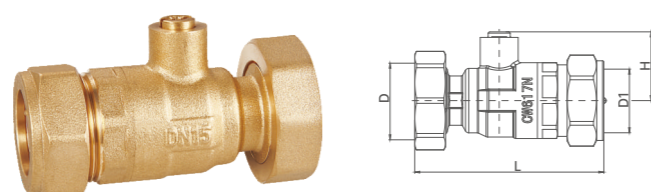

Code	D	D1	L	H
171310	1"	Ø22	75	27.5

TS 171310

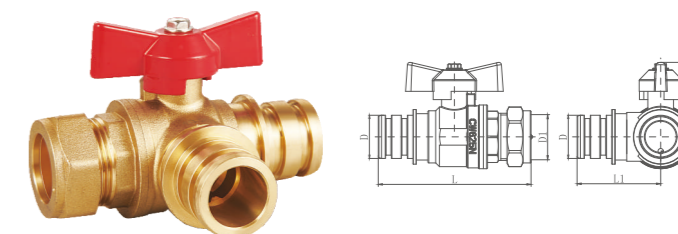

Code	D	D1	L1	L	H
171315	Ø26.1	Ø22	50.5	92.5	45.5

TS 171315

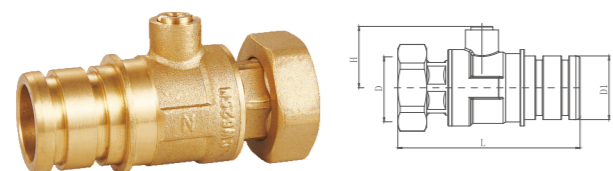

TS 171311

Code	D	D1	L	H
171311	1"	Ø30.8	88.5	30



TS 171316

Code	D	D1	D2	L	H
171316	Ø26.1	3/4"	1"	40	95

Ball Valves

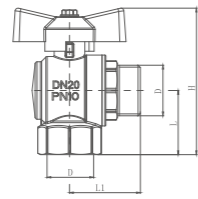

TS 171317

Code	D	L1	L	H
171317	3/4"	37	33.5	76.5

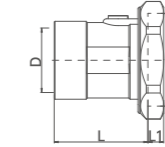
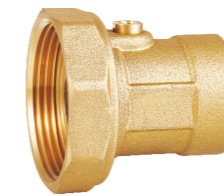

TS 171800

Code	D	D1	L1	L
171800	1"	1 1/2"	9	45

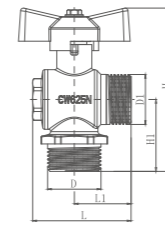

Code	D	D1	L1	L	H1	H
171318	1 1/8"	3/4"	30	52	38	86.5

TS 171318

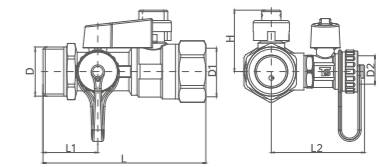
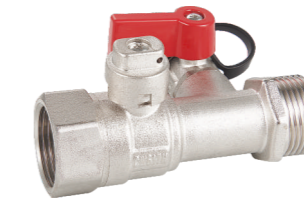

Code	D	D1	D2	L1	L2	L	H
171801	1"	1"	3/4"	37	63	110	41.5

TS 171801

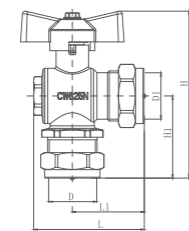

TS 171319

Code	D	D1	L1	L	H1	H
171319	Ø22	Ø22	41	63	47	95

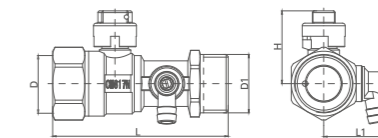

TS 171802

Code	D	D1	L1	L	H
171802	1"	1"	41	100	41.5

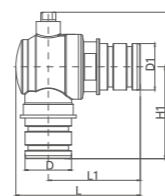

Code	D	D1	L1	L	H1	H
171320	Ø30.8	Ø30.8	61	83	61	97

TS 171320

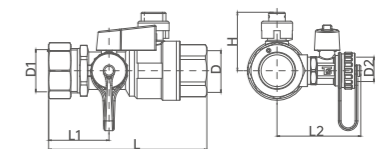

Code	D	D1	D2	L1	L2	L	H
171803	1"	28	3/4"	47.5	66	124.5	46

TS 171803

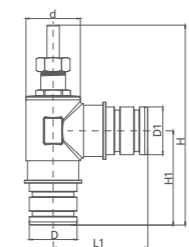

TS 171321

Code	D	D1	L1	H1	H	d
171321	Ø30.8	Ø30.8	61	61	129	35

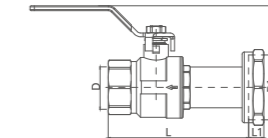
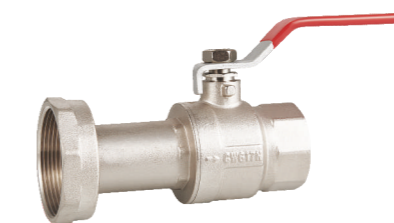

TS 171804

Code	D	D1	L1	L	H
171804	1 1/4"	2"	13.5	129.5	75

Filter Valves

Filter valves are ball valves with an integrated filter suitable for heating, cooling and tap water systems. The filter is easy to clean, just close the ball valve, unscrew the lid and remove the filter. The valve requires no maintenance, but the installation should still be checked regularly.

Technical features

max working pressure 16 bar
 max working temperature 120°C
 thread standard ISO 228/1

construction

body CW617N/CW625N
 ball CW614N/CW617N(Chrome plated)
 seal EPDM
 filter screen SUS304

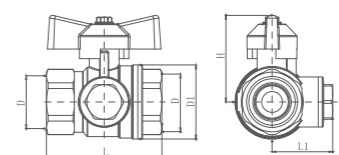

Code	D	D1	L1	L	H
172000	3/4"	Ø38.5	31.5	60	45

TS 172000

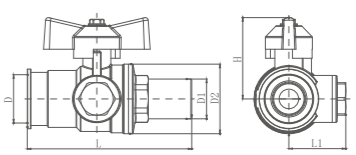

Code	D	D1	D2	L1	L	H
172001	Ø26.4	Ø22	Ø38.5	31.5	91	45

TS 172001

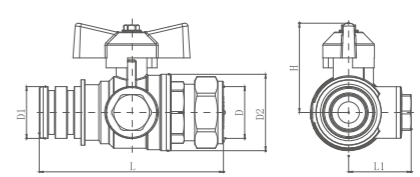
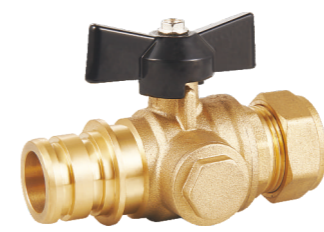

Code	D	D1	D2	L1	L	H
172002	Ø22	Ø26.1	Ø38.5	31.5	93	45

TS 172002

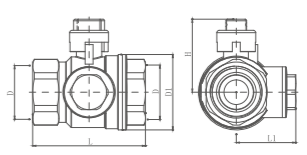

Code	D	D1	L1	L	H
172003	3/4"	Ø38.5	31.5	60	42
172003	1"	Ø47.5	37.5	71	46
172003	1 1/4"	Ø58	46	84	53.5
172003	1 1/2"	Ø69	53	93	60.5
172003	2"	Ø84.5	62	119	68.5

TS 172003

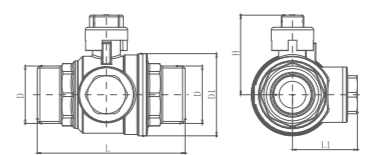
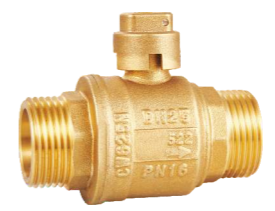

Code	D	D1	L1	L	H
172004	3/4"	Ø38.5	31.5	74	42
172004	1"	Ø47.5	37.5	85.5	46

TS 172004

Filter Valves

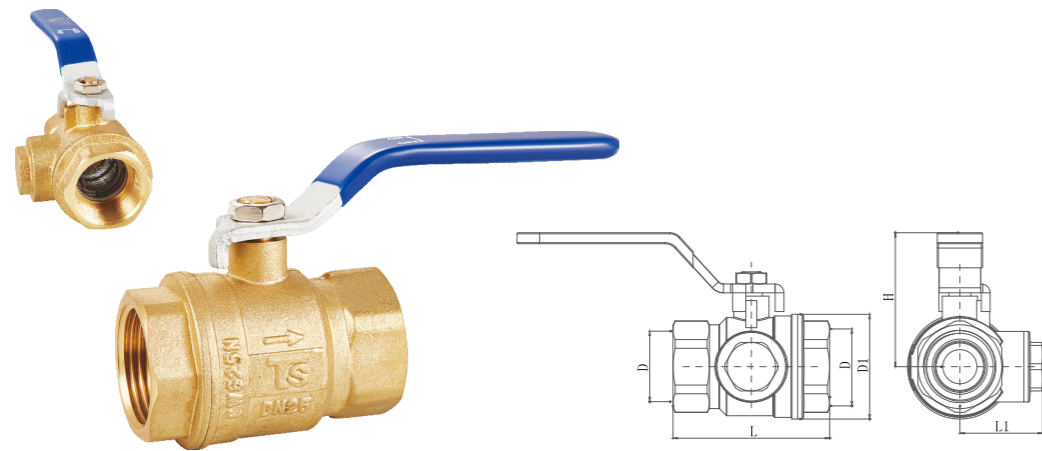

Code	D	D1	L1	L	H
172005	3/4"	Ø38.5	31.5	60	52
172005	1"	Ø47.5	37.5	71	61
172005	1 1/4"	Ø58	46	84	69
172005	1 1/2"	Ø69	53	93	86
172005	2"	Ø84.5	62	119	96

TS 172005

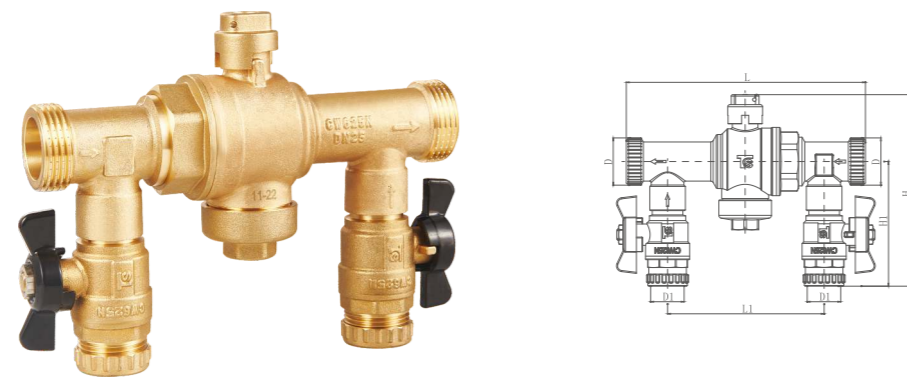

Code	D	D1	L1	L	H1	H
172100	1"	3/4"	110	168	88	135
172100	1 1/4"	3/4"	118	177	91.5	145.5

TS 172100

Fittings

Fittings are for system piping installation.

Technical features

max working pressure 16 bar
 max working temperature 120°C
 thread standard ISO 228/1

construction

body CW617N/CW625N



Fittings

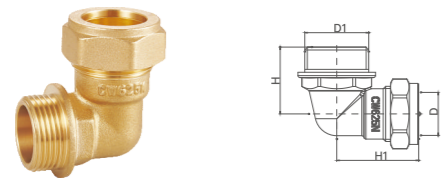

TS 174000

Code	D	D1	H	H1
174000	Ø22	3/4"	31.5	39.5
174000	Ø22	1"	34.5	42.5
174000	Ø28	1"	38.5	44

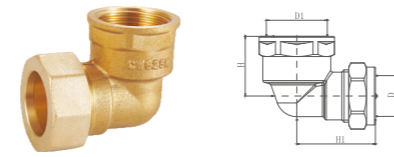

TS 174001

Code	D	D1	H	H1
174001	Ø22	3/4"	30.5	40.5
174001	Ø22	1"	32.5	43
174001	Ø28	1"	36.5	44.5

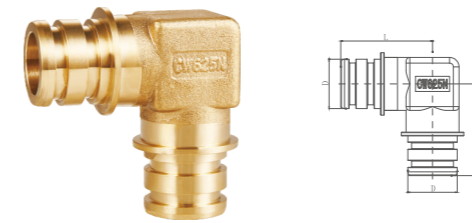

TS 174010

Code	D	L
174010	Ø26.1	48.5
174010	Ø30.8	57.5

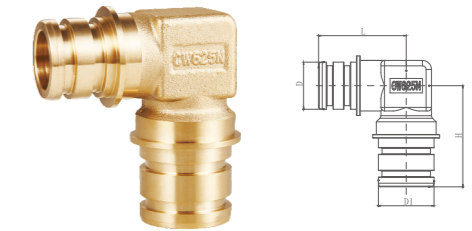

TS 174011

Code	D	D1	L	H
174011	Ø26.1	Ø30.8	48.5	56

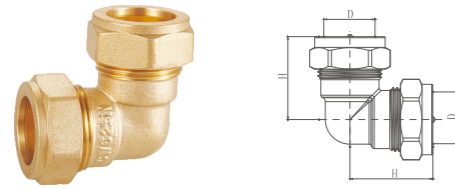

TS 174002

Code	D	H
174002	Ø15	30
174002	Ø22	37.5
174002	Ø28	43

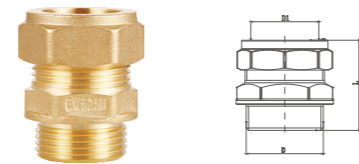

TS 174004

Code	D	D1	L
174004	1/2"	Ø15	35
174004	3/4"	Ø22	42
174004	1"	Ø28	46.5
174004	1 1/2"	Ø42	58.5

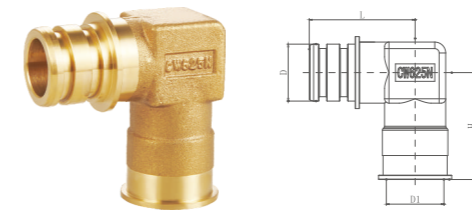

TS 174012

Code	D	D1	L	H
174012	Ø26.1	Ø26.4	48.5	49

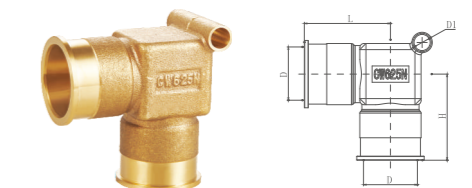

TS 174013

Code	D	D1	L	H
174013	Ø26.4	Ø8	42.5	42.5

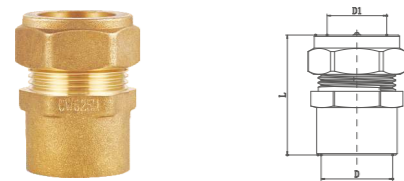

TS 174005

Code	D	D1	L
174005	3/4"	Ø22	44
174005	1"	Ø28	52

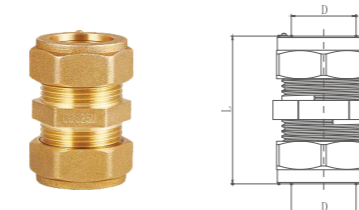

TS 174006

Code	D	L
174006	Ø15	44
174006	Ø22	49
174006	Ø28	55

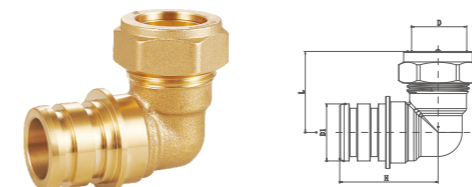

TS 174014

Code	D	D1	L	H
174014	Ø22	Ø26.1	37	45



TS 174015

Code	D	D1	L	H
174015	1"	Ø26.1	35	55

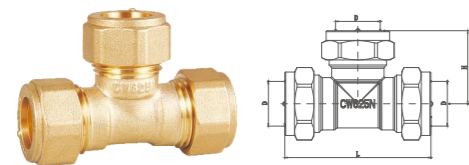

TS 174007

Code	D	H	L
174007	Ø15	30	61.5
174007	Ø22	36.5	72.5
174007	Ø28	42.5	85



TS 174009

Code	D	D1	H
174009	3/4"	Ø26.1	49
174009	1"	Ø30.8	65

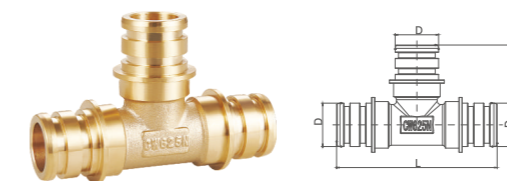

TS 174016

Code	D	L	H
174016	Ø26.1	96.5	48
174016	Ø30.8	115	57.5

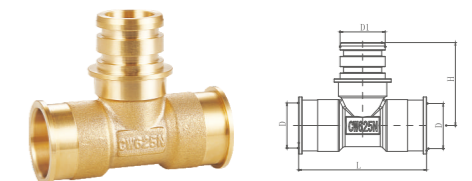

TS 174017

Code	D	D1	L	H
174017	Ø26.4	Ø26.1	74	48

Fittings

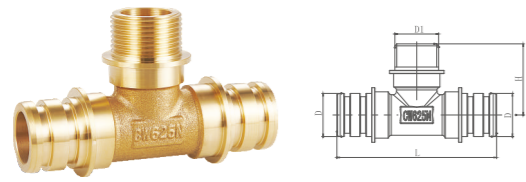

TS 174018

Code	D	D1	L	H
174018	Ø26.1	3/4"	96.5	43

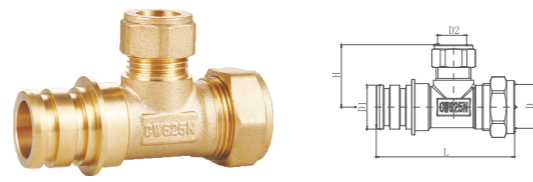

TS 174019

Code	D	D1	D2	L	H
174019	Ø22	Ø26.1	Ø15	82.5	37.5

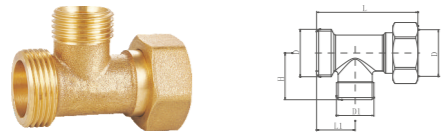

TS 174021

Code	D	D1	L1	L	H
174021	3/4"	1/2"	21.5	56	26

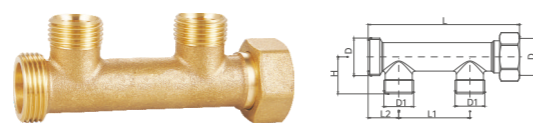

TS 174022

Code	D	D1	L1	L2	L	H
174022	3/4"	1/2"	50	21.5	106	26

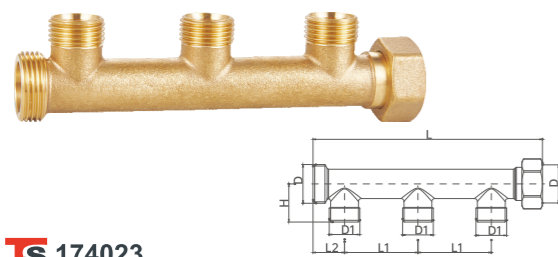

TS 174023

Code	D	D1	L1	L2	L	H
174023	3/4"	1/2"	50	21.5	156	26



TS 174024

Code	D	D1	L1	L2	L	H
174024	3/4"	1/2"	50	21.5	106	26



TS 174025

Code	D	D1	L1	L2	L	H
174025	3/4"	Ø14.5	27	23	100	30

Heating System Accessories



Bypass valve

The differential pressure bypass valve is installed between the water supply and return pipes which used to maintain a minimum flow rate or to control differential pressure in a heating system.

The closing of radiator or zone valves due to reduced heating demand may result in low flow and increased system differential pressure (potentially dead heating pumps). valves open with a falling system load and allow flow through a bypass line whenever the differential pressure through the valve exceeds set point; ensuring a minimum flow rate or a system differential pressure at minimum system load.

Technical features

working pressure range 0.1bar-0.5bar

max working temperature 120°C

construction

body CW617N

seal PPO

spring SUS304

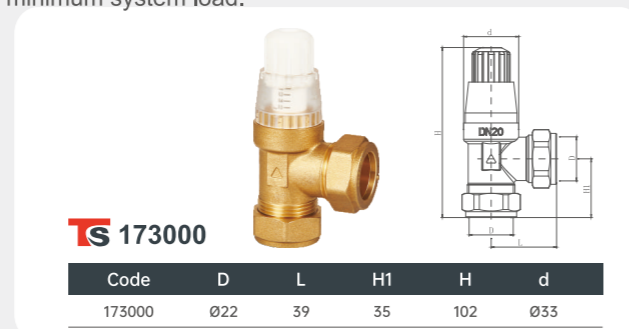

Vacuum valve

The vacuum valve is used with the heating water tank. When the system pressure is suddenly reduced to negative pressure, the vacuum valve opens the valve through the pressure difference between the atmospheric pressure and the system negative pressure, and the external pressure is introduced into the system to ensure that the system will not be affected by the negative pressure.

Technical features

max working temperature 120°C

thread standard ISO 228/1

construction

body CW625N

seal EPDM

spring SUS304

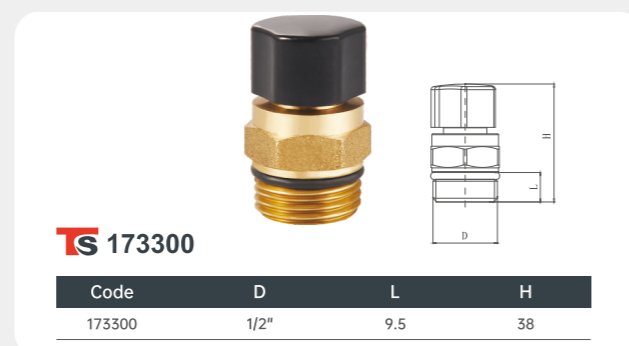

Drain valves

The drain valve is mainly used to clean up the remaining dirt in the pipeline by discharging steam and water from the system

Technical features

max working pressure 16 bar

max working temperature 90°C

thread standard ISO 228/1

construction

body CW617N

valve rod CW617N

seal EPDM

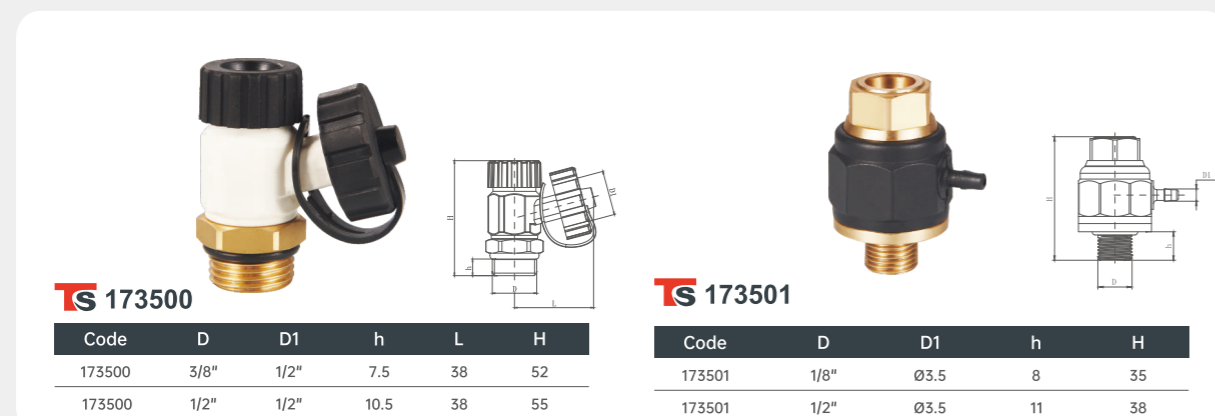

Heating tube flange

Electric heating system accessories, and electric heat pipe to form a complete heating element.

Technical features

max working pressure 16bar

thread standard ISO 228/1

construction

body CW617N

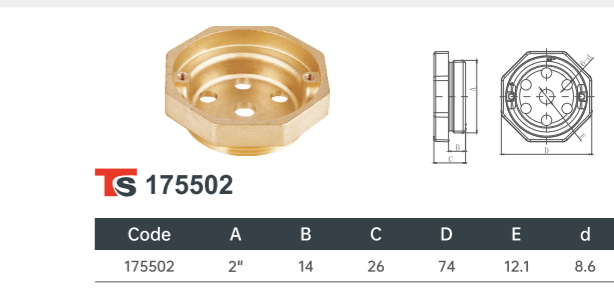
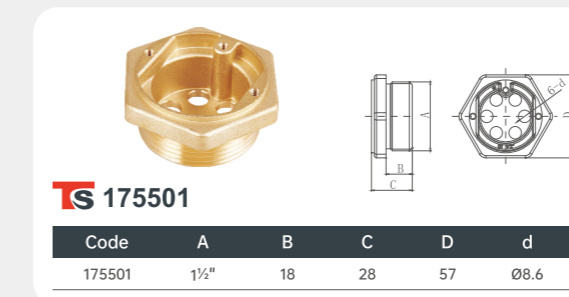
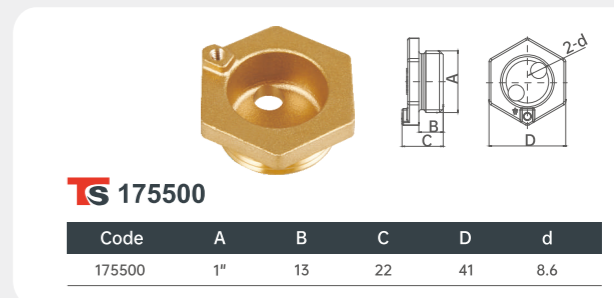

Tubing accessories

Tubing accessory is composed of manual exhaust valve and quick connector and PA12 pipe. It has good flexibility in the system and can be bent freely, which can realize quick connection and manual exhaust function

Technical features

max working pressure 6bar

max working temperature 95°C

construction

body CW617N tube PA12

seal EPDM



Check Valves

Check valves are used in the pipeline system, can realize one-way flow, non-return function.

Technical features

max working pressure 10bar
 max working temperature 65°C
 open pressure ≤0.2bar

construction

body CW617N/CW625N
 bonnet CW617N/CW625N
 seal EPDM
 spring SUS304

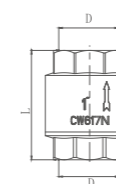

TS 176000

Code	D	L
176000	1"	59



TS 176001

Code	D	D1	L
176001	1"	ø26.4	66.5



TS 176002

Code	D	D1	L
176002	ø26.1	ø26.4	90.5



TS 176003

Code	D	L
176003	ø26.1	106.5

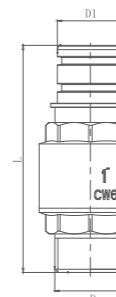

TS 176004

Code	D	D1	L
176004	1"	ø30.8	106

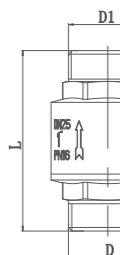

TS 176005

Code	D	D1	L
176005	1"	1"	76

DSC_2064

Air Vents

Automatic air vent valves are designed to remove the air that accumulates in heating and air conditioning systems without the need for manual intervention. This prevents harmful phenomena that may compromise the life and the performance of the heating system and which include: corrosion due to the oxygen; pockets of air trapped in the heating emitters; cavitation in the circulation pumps.

Technical features

max working pressure 10 bar
 max water temperature 115°C
 thread standard ISO 228/1

construction

body CW617N
 vent CW617N
 seal EPDM
 floater PP

Pressure reducing valves

Pressure reducing valves are devices installed in a water system to reduce and stabilize the incoming pressure from the water supply, it must maintain a constant downstream pressure in the face of upstream pressure fluctuations.

Technical features

max working pressure 25 bar
 downstream pressure setting range 1-6bar
 max water temperature 80°C
 thread standard ISO 228/1
 gauge connection ISO 7/1

construction

body CW617N/CW625N
 diaphragm NBR
 seal seat SUS304
 spring carbon steel C72

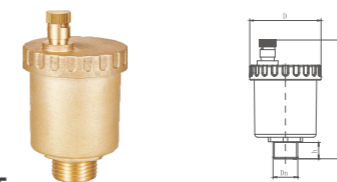

TS 5301T

Code	Dn	H	h	D
5301T	3/8"	80	11	Ø48
5301T	1/2"	80	11	Ø48
5301T	3/4"	80	11	Ø48
5301T	1"	81.5	12	Ø48

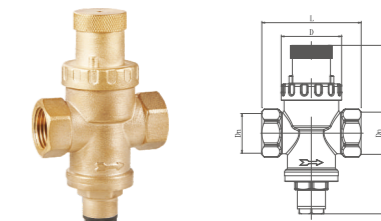

TS 501T

Code	Dn	L	D	H
501T	1/2"	60	Ø36	104
501T	3/4"	60	Ø36	104



TS 5302T

Code	Dn	H	h	D
5302T	3/8"	77	10	Ø40
5302T	1/2"	77	11	Ø40

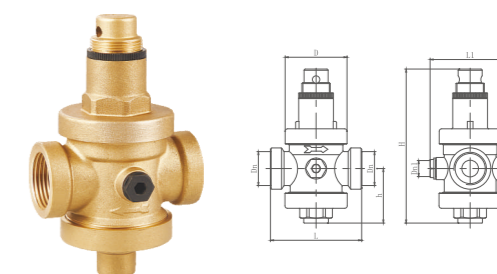

TS 503

Code	Dn	Dn1	D	h	L1	L	H
503	1/2"	1/4"	Ø50	45	65	77	125
503	3/4"	1/4"	Ø50	45	65	76	125
503	1"	1/4"	Ø64	61	75	90	150
503	1 1/4"	1/4"	Ø71	71	93	108	210
503	1 1/2"	1/4"	Ø71	71	93	112	210
503	2"	1/4"	Ø71	81	110	138	245

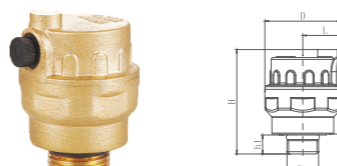

TS 5303T

Code	Dn	H	h	h1	L	D
5303T	1/4"	55	45	10	25	Ø40
5303T	3/8"	55	45	10	25	Ø40
5303T	1/2"	55	45	10	25	Ø40

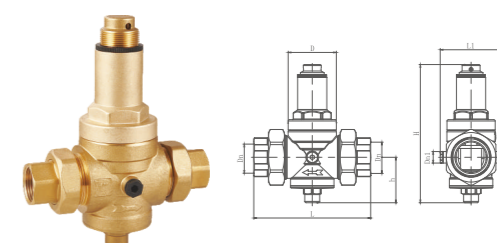

TS 513

Code	Dn	Dn1	D	h	L1	L	H
513	1/2"	1/4"	Ø50	45	65	114	125
513	3/4"	1/4"	Ø64	61	75	131	150
513	1"	1/4"	Ø64	67	91	171	220
513	1 1/4"	1/4"	Ø71	67	91	171	220
513	1 1/2"	1/4"	Ø71	67	91	172	220
513	2"	1/4"	Ø71	67	109	191	245

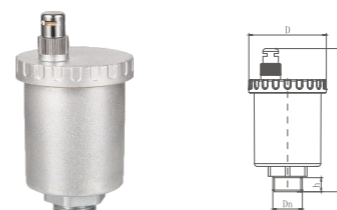

TS 5301T-B

Code	Dn	H	h	D
5301T-B	3/8"	101	10	Ø55
5301T-B	1/2"	102.5	10	Ø48
5301T-B	3/4"	102.5	10	Ø48
5301T-B	1"	105	12	Ø48

Assembled Wall Mounting Manifolds

Assembled Wall Mounting Manifolds are multifunctional combination valves that integrates a safety valve, automatic air vent and pressure gauge. Suitable for boiler and heat pump systems. In order to ensure the safety of the whole system, it can automatically exhaust the gas in the system and prevent overpressure, real-time pressure display

Technical features

Safety valve setting pressure	3bar
Air vent	3/8"
pressure gauge BSP1/4"	63MM
pressure range of pressure gauge	(0-4)bar
max working temperature	110°C

construction

body	CW614N/CW617N
seal	EPDM/PTFE
Pressure gauge cover	PC

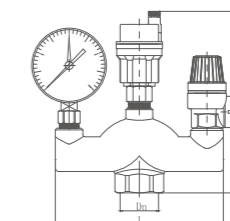

TS 701

Code	Dn	L	H
701	1"	145	157

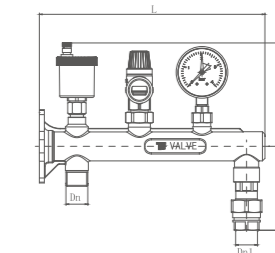
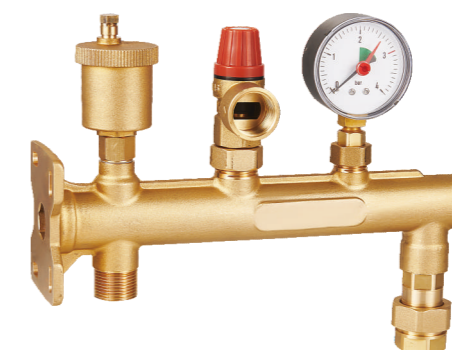

Code	Dn	Dn1	H1	H	L
702	3/4"	3/4"	101	225	271

TS 702

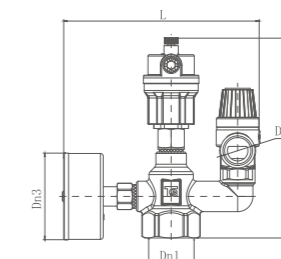

TS 704

Code	Dn1	Dn2	Dn3	H	L
704	1"	1/2"	Ø63	144	141

Actuators

The actuator is used together with the matching valve, which can be used to automatically adjust the medium flow direction and the system opening and closing in the air conditioning system or indoor water system. Suitable for operating rotary mixing valve DN15-32. Rotating angle range is 60 or 90°, the series can be used for 2-point, 3-point and 0-10V control signals, some models can be easily manually operated by the button on the front of the actuator.

Technical features

power supply: 230 VAC 50Hz / 24 VAC 50Hz
 max torque: 5 Nm
 enclosure protection class: IP50/IP54
 rotation angle: 60°/90°
 connection: cable 1 m, 3 x 0,75 mm²/connector
 ambient temperature: 0°C..+55°C
 ambient humidity: 0%..80% R.H. (non-condensed)

construction

enclosure: PA66
 locking disk: POM
 spring: SUS304

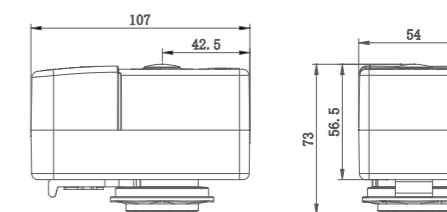

Code	Reference	Power supply	Control signal	Angle	Connection	Manual control
180000	T50KS-C 2P ND	230V 50Hz	2-point SPST	8s/60°	cable	NO
180001	T50KS-M 2P ND	230V 50Hz	2-point SPST	8s/60°	terminal connection	NO
180003	T50PN-C 2P ND	230V 50Hz	2-point SPST	12s/90°	cable	NO
180004	T50PN-M 2P ND	230V 50Hz	2-point SPST	12s/90°	terminal connection	NO
180005	T50EN-C 2P	230V 50Hz	2-point SPST	20s/90°	cable	NO
180006	T50EN-M 2P	230V 50Hz	2-point SPST	20s/90°	terminal connection	NO
180007	T50EN-C 3P	230V 50Hz	3-point SPDT	20s/90°	cable	NO
180008	T50EN-M 3P	230V 50Hz	3-point SPDT	20s/90°	terminal connection	NO

TS T5000 Series

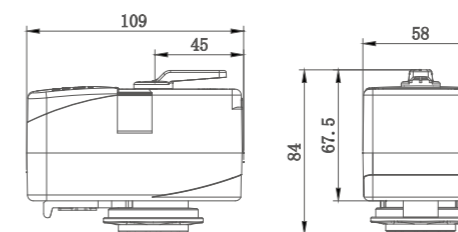

Code	Reference	Power supply	Control signal	Angle	Connection	Manual control
180008	T60KS-C 2P ND	230V 50Hz	2-point SPST	8s/60°	cable	NO
180009	T60KS-M 2P ND	230V 50Hz	2-point SPST	8s/60°	terminal connection	NO
180010	T61KS-C 2P ND	230V 50Hz	2-point SPST	8s/60°	cable	YES
180011	T61KS-M 2P ND	230V 50Hz	2-point SPST	8s/60°	terminal connection	YES
180012	T60PN-C 2P ND	230V 50Hz	2-point SPST	12s/90°	cable	NO
180013	T60PN-M 2P ND	230V 50Hz	2-point SPST	12s/90°	terminal connection	NO
180014	T61PN-C 2P ND	230V 50Hz	2-point SPST	12s/90°	cable	YES
180015	T61PN-M 2P ND	230V 50Hz	2-point SPST	12s/90°	terminal connection	YES
180016	T60JN-C 2P ND	230V 50Hz	2-point SPST	30s/90°	cable	NO
180017	T60JN-M 2P ND	230V 50Hz	2-point SPST	30s/90°	terminal connection	NO
180018	T61JN-C 2P ND	230V 50Hz	2-point SPST	30s/90°	cable	YES
180019	T61JN-M 2P ND	230V 50Hz	2-point SPST	30s/90°	terminal connection	YES
180020	T60EN-C 2P	230V 50Hz	2-point SPST	20s/90°	cable	NO
180021	T60EN-M 2P	230V 50Hz	2-point SPST	20s/90°	terminal connection	NO
180022	T62EN-C 2P	230V 50Hz	2-point SPST	20s/90°	cable	YES
180023	T62EN-M 2P	230V 50Hz	2-point SPST	20s/90°	terminal connection	YES
180024	T62HN-C 3P	230V 50Hz	3-point SPDT	110s/90°	cable	YES
180025	T62HN-M 3P	230V 50Hz	3-point SPDT	110s/90°	terminal connection	YES
180026	T60EN-C 3P	230V 50Hz	3-point SPDT	20s/90°	cable	NO
180027	T60EN-M 3P	230V 50Hz	3-point SPDT	20s/90°	terminal connection	NO
180028	T62EN-C 3P	230V 50Hz	3-point SPDT	20s/90°	cable	YES
180029	T62EN-M 3P	230V 50Hz	3-point SPDT	20s/90°	terminal connection	YES
180030	T62AN-C 3P	230V 50Hz	3-point SPDT	40s/90°	cable	YES
180031	T62AN-M 3P	230V 50Hz	3-point SPDT	40s/90°	terminal connection	YES
180032	T62BN-C 3P	230V 50Hz	3-point SPDT	55s/90°	cable	YES
180033	T62BN-M 3P	230V 50Hz	3-point SPDT	55s/90°	terminal connection	YES
180034	T62VN-C 3P	230V 50Hz	3-point SPDT	80s/90°	cable	YES
180035	T62VN-M 3P	230V 50Hz	3-point SPDT	80s/90°	terminal connection	YES
180036	T62TN-C 3P	230V 50Hz	3-point SPDT	220s/90°	cable	YES
180037	T62TN-M 3P	230V 50Hz	3-point SPDT	220s/90°	terminal connection	YES

TS T6000 Series

Pressure gauge & Temperature gauge
Function Pressure gauge accuracy grade: normal 2.5

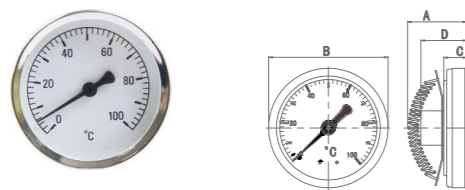

TS 641

Temp.	A(mm)	B(mm)	C(mm)	D(mm)
1-100	32	63	12	24.5

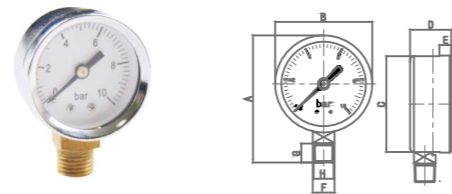

TS 652

Pre.	A(mm)	B(mm)	C(mm)	D(mm)	E(mm)	F(mm)	G(mm)	H
0-4	58	42	40.6	25.5	8.2	14	9.5	R1/4
0-6	58	42	40.6	25.5	8.2	14	9.5	R1/4
0-10	58	42	40.6	25.5	8.2	14	9.5	R1/4

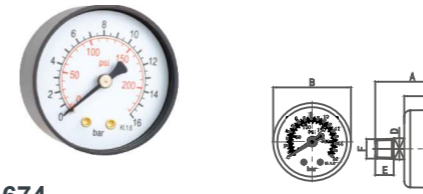

TS 674

Pre.	A(mm)	B(mm)	C(mm)	D(mm)	E(mm)	F
0-4	45.7	51.5	27.5	14	12.2	R1/4
0-10	45.7	51.5	27.5	14	12.2	R1/4
0-16	45.7	51.5	27.5	14	12.2	R1/4

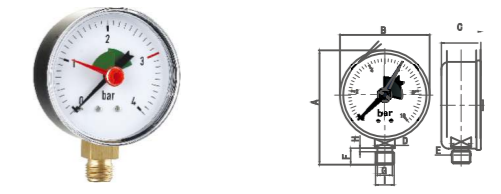

TS 675

Pre.	A(mm)	B(mm)	C(mm)	D(mm)	E(mm)	F(mm)	G(mm)	H(mm)	I
0-4	80.5	62.5	27.5	14	14	10.5	10.8	2.0	R1/4
0-6	80.5	62.5	27.5	14	14	10.5	10.8	2.0	R1/4
0-10	80.5	62.5	27.5	14	14	10.5	10.8	2.0	R1/4



TS 652

Pre.	A(mm)	B(mm)	C(mm)	D(mm)	E(mm)	F(mm)	G(mm)	H(mm)	I(mm)	J
0-4	41	42	40.6	24.5	8.2	14	9.5	12.2	2	R1/4
0-6	41	42	40.6	24.5	8.2	14	9.5	12.2	2	R1/4
0-10	41	42	40.6	24.5	8.2	14	9.5	12.2	2	R1/4

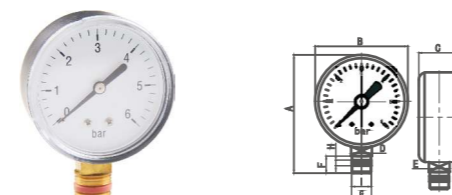

TS 653

Pre.	A(mm)	B(mm)	C(mm)	D(mm)	E(mm)	F(mm)	G(mm)	H(mm)	I
0-4	82.5	62.5	28	14	14	12	17	2.5	G3/8
0-6	82.5	62.5	28	14	14	12	17	2.5	G3/8
0-10	82.5	62.5	28	14	14	12	17	2.5	G3/8



TS 676

Pre.	A(mm)	B(mm)	C(mm)	D(mm)	E(mm)	F
0-4	45.7	62.5	27.5	14	12.2	R1/4
0-10	45.7	62.5	27.5	14	12.2	R1/4
0-16	45.7	62.5	27.5	14	12.2	R1/4

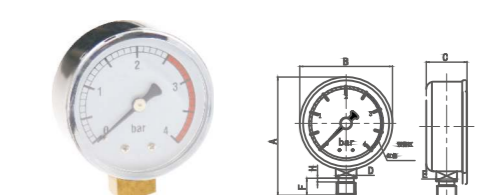

TS 677

Pre.	A(mm)	B(mm)	C(mm)	D(mm)	E(mm)	F(mm)	G(mm)	H(mm)	I
0-4	69	51.5	26.5	14	14	12	10.5	2.5	G1/4



TS 654

42mm									
Temp.	A(mm)	B(mm)	C(mm)	D(mm)	E(mm)	F(mm)	G(mm)	H	
0-80	43.5	42	10.5	SW16	19	8	10.4	G1/4	
0-120	43.5	42	10.5	SW16	19	8	10.4	G1/4	

63mm									
Temp.	A(mm)	B(mm)	C(mm)	D(mm)	E(mm)	F(mm)	G(mm)	H	
0-80	62	63	12	SW21.5	29.5	13	10.4	G1/2	
0-120	62	63	12	SW21.5	29.5	13	10.4	G1/2	

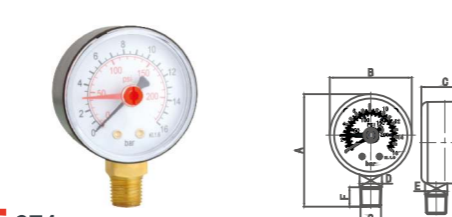

TS 671

Pre.	A(mm)	B(mm)	C(mm)	D(mm)	E(mm)	F(mm)	G
0-4	70.5	51.5	26.5	14	14	12.2	R1/4
0-10	70.5	51.5	26.5	14	14	12.2	R1/4
0-16	70.5	51.5	26.5	14	14	12.2	R1/4

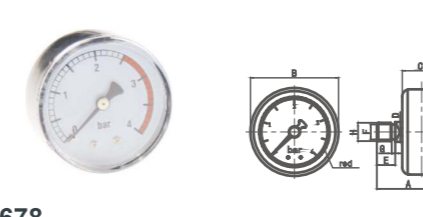

TS 678

Pre.	A(mm)	B(mm)	C(mm)	D(mm)	E(mm)	F(mm)	G(mm)	H
0-4	45.5	51.5	26.5	14	13	10.6	2.5	G1/4

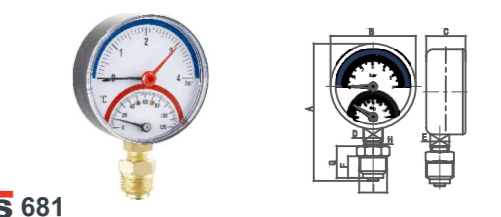

TS 681

Pre.	A(mm)	B(mm)	C(mm)	D(mm)	E(mm)	F(mm)	G(mm)	H	I
0-4	113	80.5	30	14	14	15	23.5	G1/4	G1/2
0-6	100	63	29	14	14	15	23.5	G1/4	G1/2
0-10	100	63	29	14	14	15	23.5	G1/4	G1/2
0-10	88	52	29	14	14	15	23.5	G1/4	G1/2

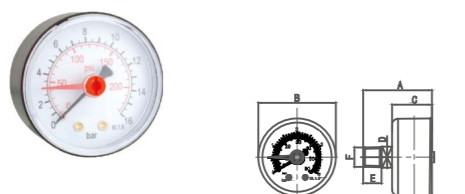

TS 672

Pre.	A(mm)	B(mm)	C(mm)	D(mm)	E(mm)	F
0-4	44	51.5	26	14	11	R1/4
0-10	44	51.5	26	14	11	R1/4
0-16	44	51.5	26	14	11	R1/4

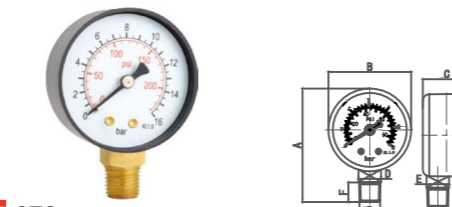

TS 673

Pre.	A(mm)	B(mm)	C(mm)	D(mm)	E(mm)	F(mm)	G
0-4	70.5	51.5	26.5	14	14	12.2	R1/4
0-10	70.5	51.5	26.5	14	14	12.2	R1/4
0-16	70.5	51.5	26.5	14	14	12.2	R1/4



TS 682

Pre.	A(mm)	B(mm)	C(mm)	D(mm)	E(mm)	F(mm)	G	H
0-4	63	80.5	29	14	15	23.5	G1/4	G1/2
0-6	66	63	28	14	15	23.5	G1/4	G1/2
0-10	66	63	28	14	15	23.5	G1/4	G1/2
0-10	63	52	28	14	15	23.5	G1/4	G1/2



TS 684

Pre.	A(mm)	B(mm)	C(mm)	D(mm)	E(mm)	F(mm)	G(mm)	H
0-80	72	63	28	14	26	10	8.6	G1/4
0-120	72	63	28	14	26	10	8.6	G1/4